



R230 Video Room Station

Installation & Operation Manual



Intelligent Central Systems

Trade sales
www.ness.com.au

Retail sales
www.valet.com.au

Sales, Service, Spares consumer enquiries
Ph 1300 050 333
sales@icentralsystems.com.au



iCENTRAL TRADE & DEALER ENQUIRIES

HEAD OFFICE
Ness Corporation Pty Ltd
ABN 28 069 984 372
Ph +61 2 8825 9222 Fax +61 2 9674 2520
sales@icentralsystems.com.au

www.ness.com.au

R230 Video Room Station Manual Rev1.0
Document Part No. 890-484



Note: DAB+ digital radio broadcasts may not be available in all areas.

COPYRIGHT NOTICE

All rights reserved. No part of this publication may be reproduced, transmitted or stored in a retrieval system in any form or by any means, electronic, mechanical, photocopying, recording, or otherwise, without the prior written permission of Ness.

Ness reserves the right to make changes to features and specifications at any time without prior notification in the interest of ongoing product development and improvement.

© 2019 Ness Corporation ABN 28 069 984 372

Contents

Features	4
Specifications	4
Cabling - Important information	5
Cabling Overview	
Systems without a Master station	6
Systems with a Master station	7, 8
Load resistors	9
Wiring Connections - Systems with a Master	
One Video Room station using CAT5 + RG59	10
One Video Room station using Valet cable	11
Multiple Video Room stations using CAT5 + RG59	12
Multiple Video Room stations using Valet cable	13
Wiring Connections - Systems without a Master station	
One Video Room station using CAT5 + RG59	14
One Video Room station using Valet cable	15
Multiple Video Room stations using CAT5 + RG59	16
Multiple Video Room stations using Valet cable	17
Programming	
Backlighting levels, set the station number and other options	18
Operation	
Door call / House Call / Select Call.	19
Communication Volume	19
Privacy Mode / Music Mode / Monitor Mode	20
Lock Control	20
Video Operation / Video Monitoring	20

Features

- Configurable for operation With or Without a Master
- Adjustable Keypad Backlighting
- Digital Volume Control
- Independent Volume Adjustment for Music and Communication
- Collective or Individual Communication with other internal stations
- Lock Release Control
- Audio Monitoring
- Video Monitoring
- Do Not Disturb Mode
- Privacy Mode

Specifications

Display:	5" Colour TFT LCD PAL/NTSC with 640 x 480 Resolution
Speaker:	70mm x 40mm Cloth Surround Speaker 16 Ohm
Microphone:	9.7mm Electret Microphone
Video input:	Analogue video (CVBS) 1Vp-p 75 ohm, 4:3 image ratio preferred
Voltage:	13.8Vdc
Current	330mA (450mA Peak)
Dimensions:	(W) 264mm x (H) 124.5mm
Recess:	(W) 200mm x (H) 90mm x (D) 28mm

IMPORTANT INFORMATION ABOUT CABLING

Video Room Station Cabling

Video room stations can be cabled using either CAT5 & RG59 or VALET Cable. The maximum cable length from the master (or central connection point) to each video room station is 25m.

This distance can be doubled by adding a booster supply at the video room station or by running an additional Fig-8 wire (in parallel with the standard wiring) for the POS and NEG connections.

Where a booster supply is used, fitting diodes in series with the POS and NEG outputs is recommended to ensure the booster supply voltage is slightly lower than the voltage at the main power supply.

It is important to wire the system exactly as per the wiring diagrams, particularly where Valet cable is being used.

When using Valet cable, the use of the shielded inner core conductors for video is not recommended. For best results, select and follow the appropriate wiring diagram as per this manual.

Please note that the AUX terminal is not connected when using Valet cable so Auxiliary functions are not available unless the system is programmed to Double Digit mode. This affects the activation of Auxiliary Outputs (where used) or the ability to monitor cameras from video room stations on command (where required).

Power Supply Cabling

Because video room stations consume up to three times the peak current of standard room stations, it is important to maintain a stable supply voltage at the master (or station to which all other stations are wired).

To achieve this, it is important to use a sufficient gauge of wire from the power supply to the master (or central connection point).

The required wire gauge will vary, depending on the length of the cable used.

The following guide should be followed (based on a peak load of up to 5A)

Number & Size of Strands	Maximum Length	Comment
24/0.20	1.4M	Fig-8 Cable
41/0.20	2.5MM	Fig-8 Cable
2 x 24/0.20	3M	2 x Fig-8 Cables in Parallel
79/0.20	5.0M	Fig-8 Cable
2 x 41/0.20	5.0M	2 x Fig-8 Cables in Parallel
2 x 79/0.20	10m	2 x Fig-8 Cables in Parallel

Where a power supply comes with an output lead already attached, cut the attached lead to 20cm and then connect to the recommended Fig-8 cable as per the above guide.

System Cabling – No Master One Video Room

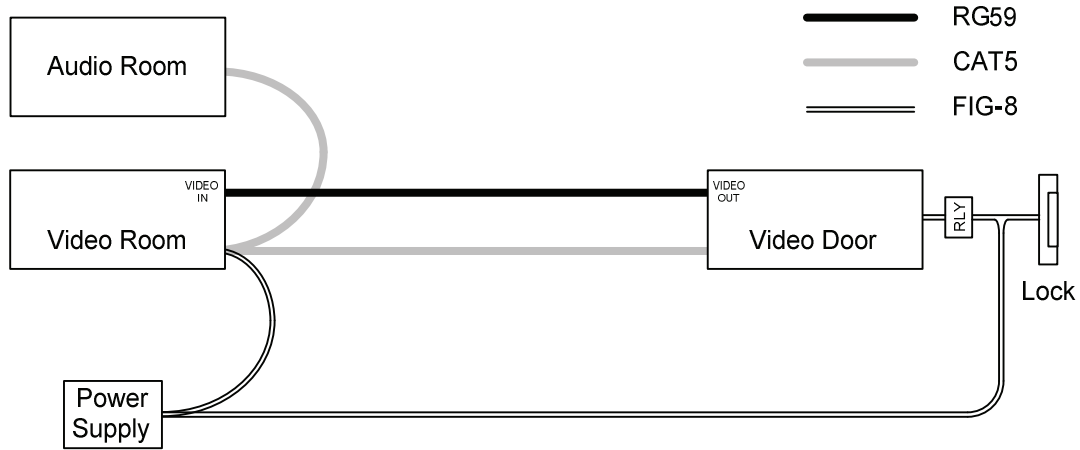

System Cabling – No Master Multiple Video Rooms

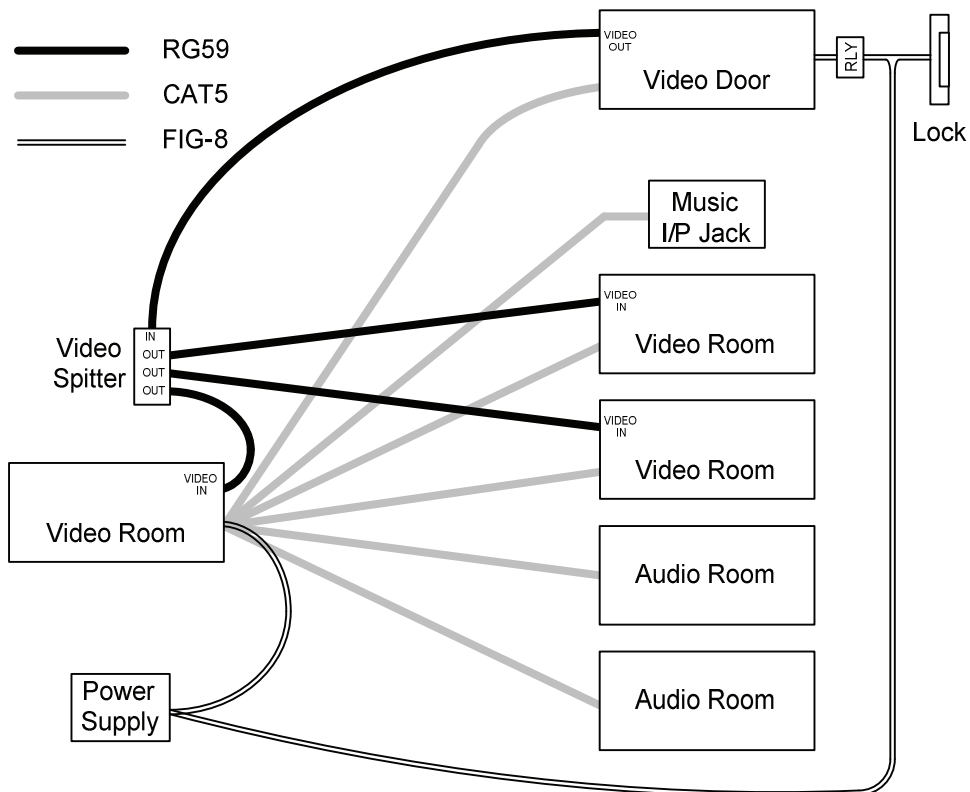

System Cabling – With Master One Video Room

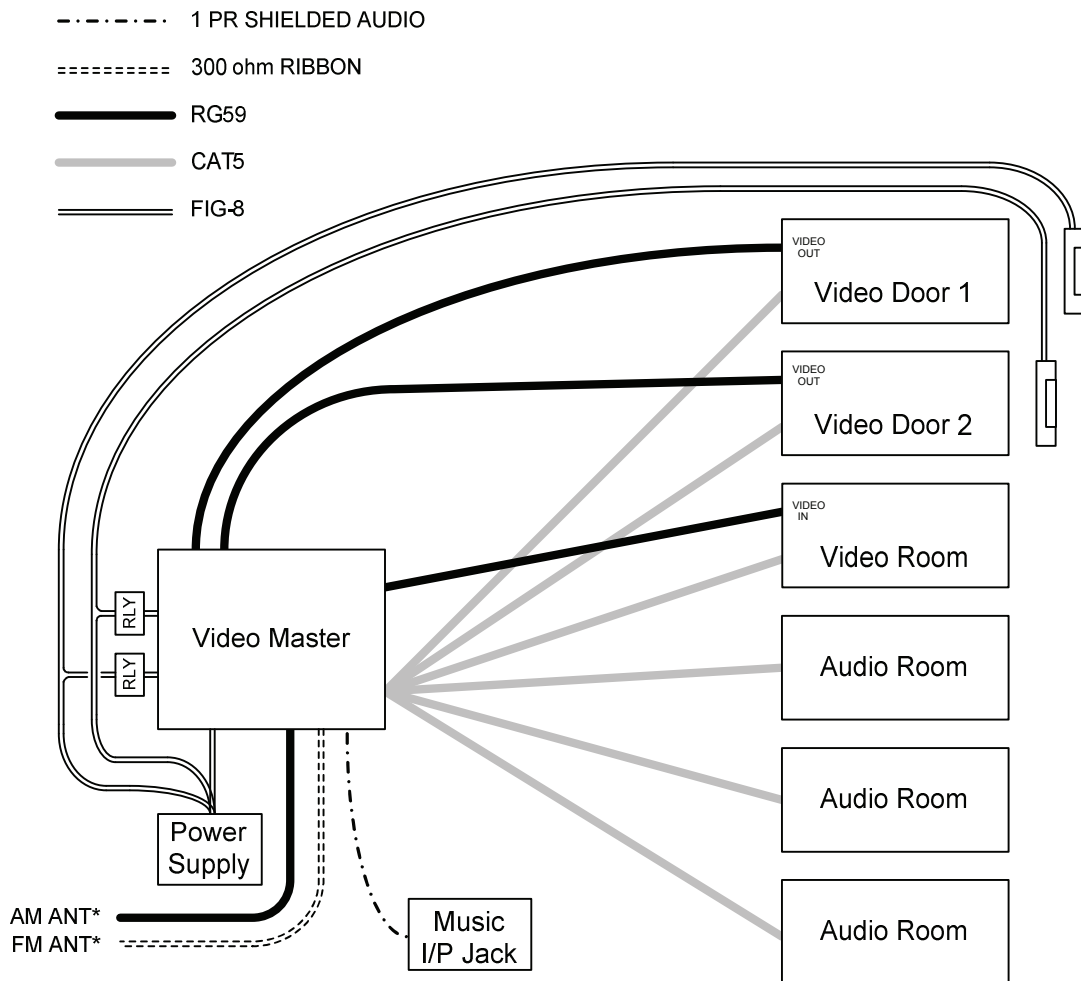

*For DAB Radio, RG59 & 300 ohm Ribbon are not required. Use 1 x RG6 instead

*Video Splitter only required for multiple video room stations

System Cabling – With Master Multiple Video Rooms

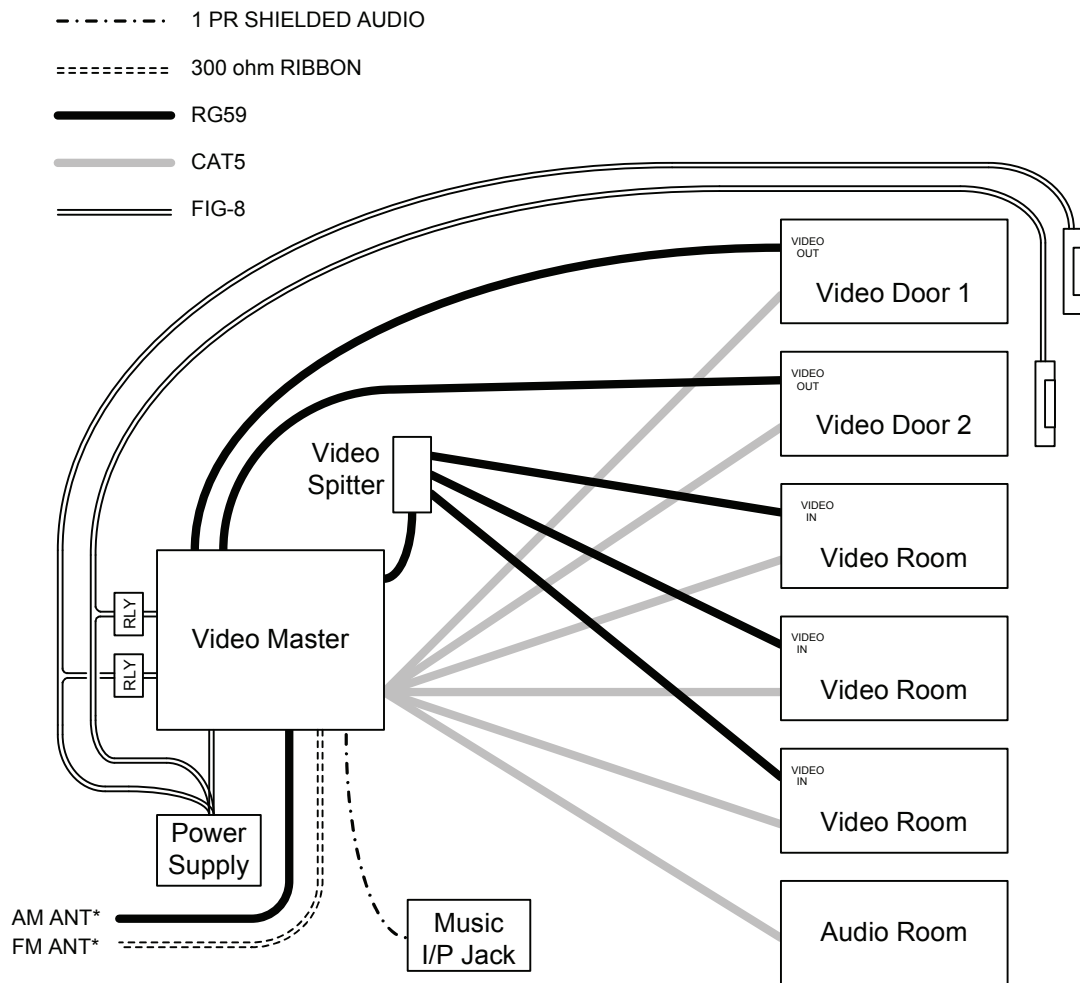

* For DAB Radio, RG59 & 300 ohm Ribbon are not required. Use 1 x RG6 instead

* Video Splitter only required for multiple video room stations

AUDIO & VLC LOAD RESISTORS

Audio Volume Level Compensation – for smaller systems

System One communication volume levels are optimal in systems consisting of 7 stations in total (Any combination of Master, Room and Door stations)

For smaller systems (consisting of less than 7 stations in total), a resistor can be added across the COM1 & COM2 terminals (at one station only) to add the appropriate amount of loading, as follows.

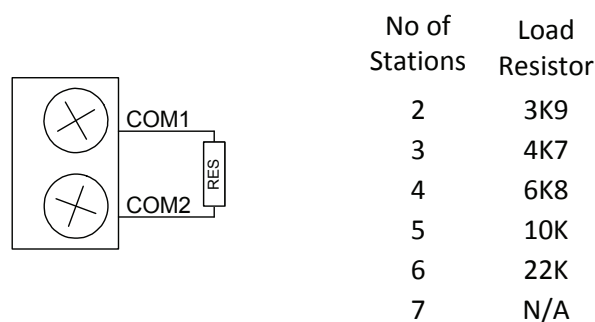

VLC Load Resistor – for systems not using a master station

System One requires a load resistor from VLC to NEG for the system to transmit and receive control signals correctly.

Master stations have a built in load resistor so systems using a master do not require an additional load resistor.

For systems not using a master (i.e. systems using just room and door stations), a 22K resistor will need to be fitted across the NEG and VLC terminals at one station only.

(This resistor would usually be fitted at the room station to which the power supply is connected)

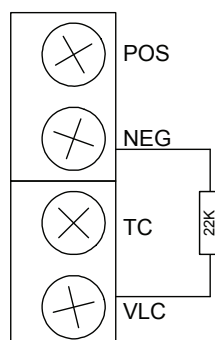

INSTALLATION

Connections (System with a Master)

Master to Video Room
Using CAT5 + RG59 Cables
*** No Video Splitter**
(for Connecting Only One Video Room)

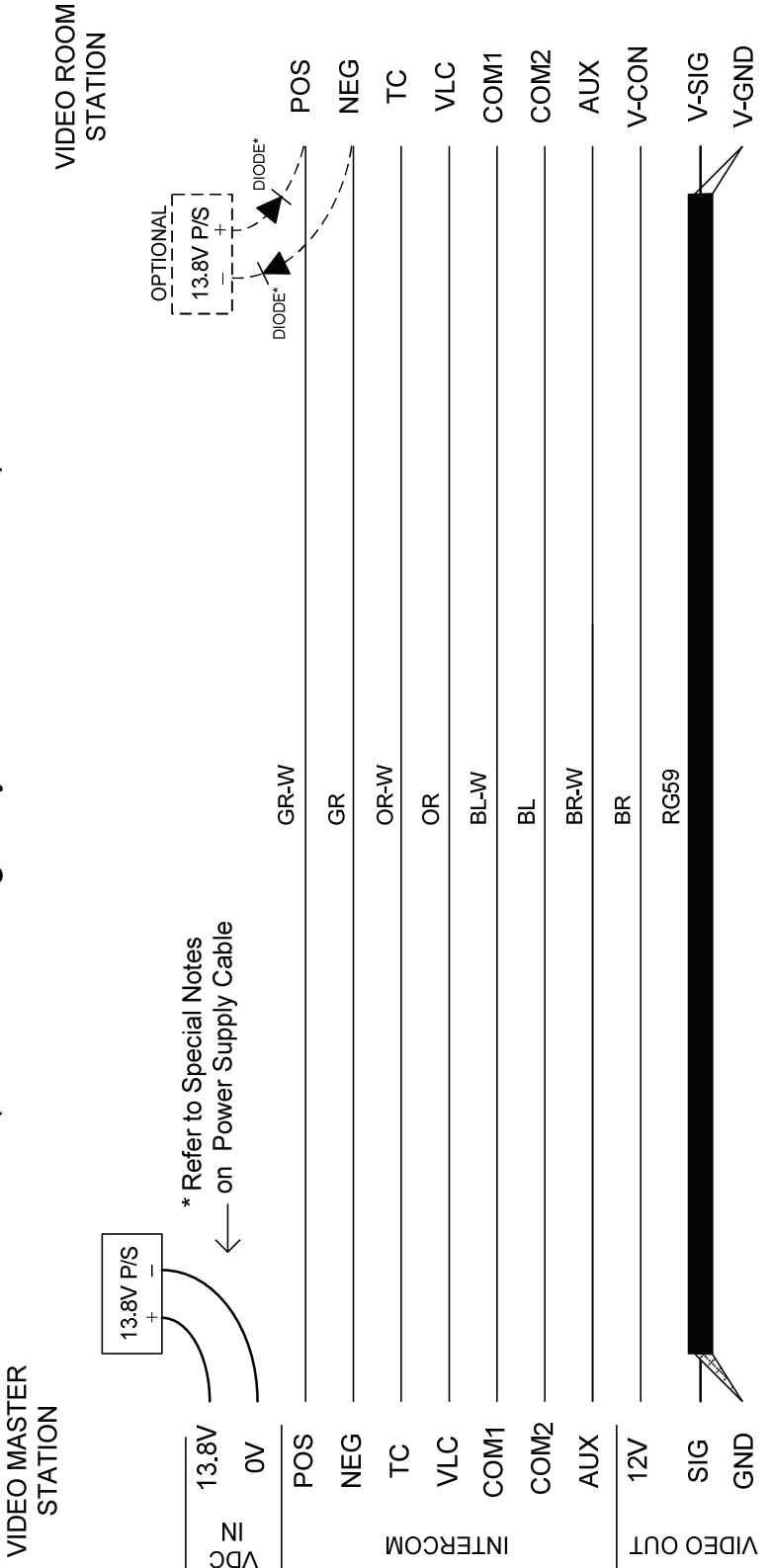

* If optional booster supply fitted to video room station, 2 diodes will need to be fitted as illustrated. Recommended diode: 1N4001 or 1N4002 or 1N4004

* Be sure to load the audio lines with the appropriate resistor in relation to the total number of stations connected — See page 9

Connections (System with a Master)

Master to Video Room Using VALET Cable * No Video Splitter (for Connecting Only One Video Room)

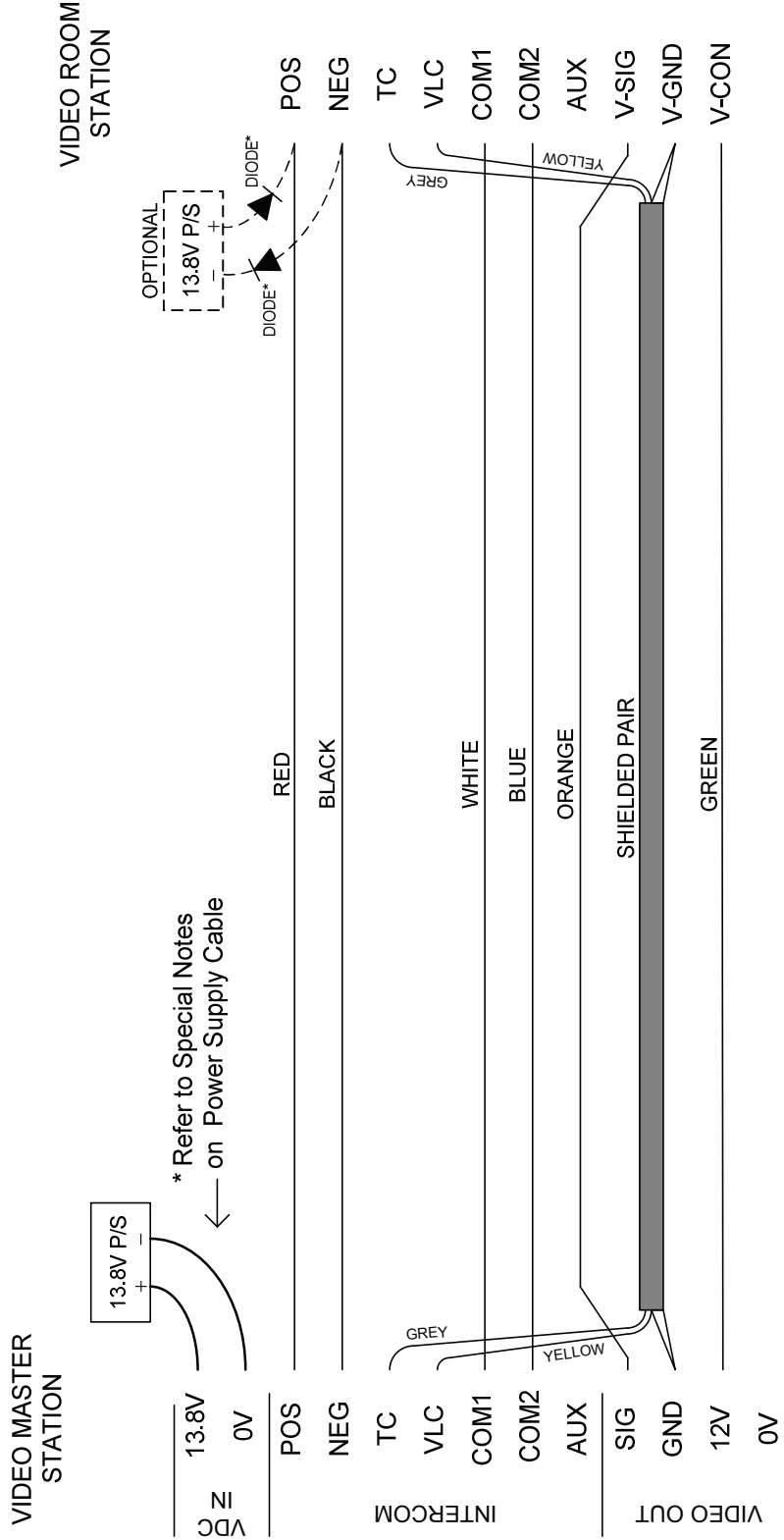

* If optional booster supply fitted to video room station, 2 diodes will need to be fitted as illustrated.
 Recommended diode: 1N4001 or 1N4002 or 1N4004

* Be sure to load the audio lines with the appropriate resistor in relation to the total number of stations connected – See page 9

- MASTER
- MULTIPLE VIDEO ROOMS
- CAT5 + RG59

Connections (System with a Master)

Master to Video Room Using CAT5 + RG59 Cables and Video Splitter (for Multiple Video Rooms)

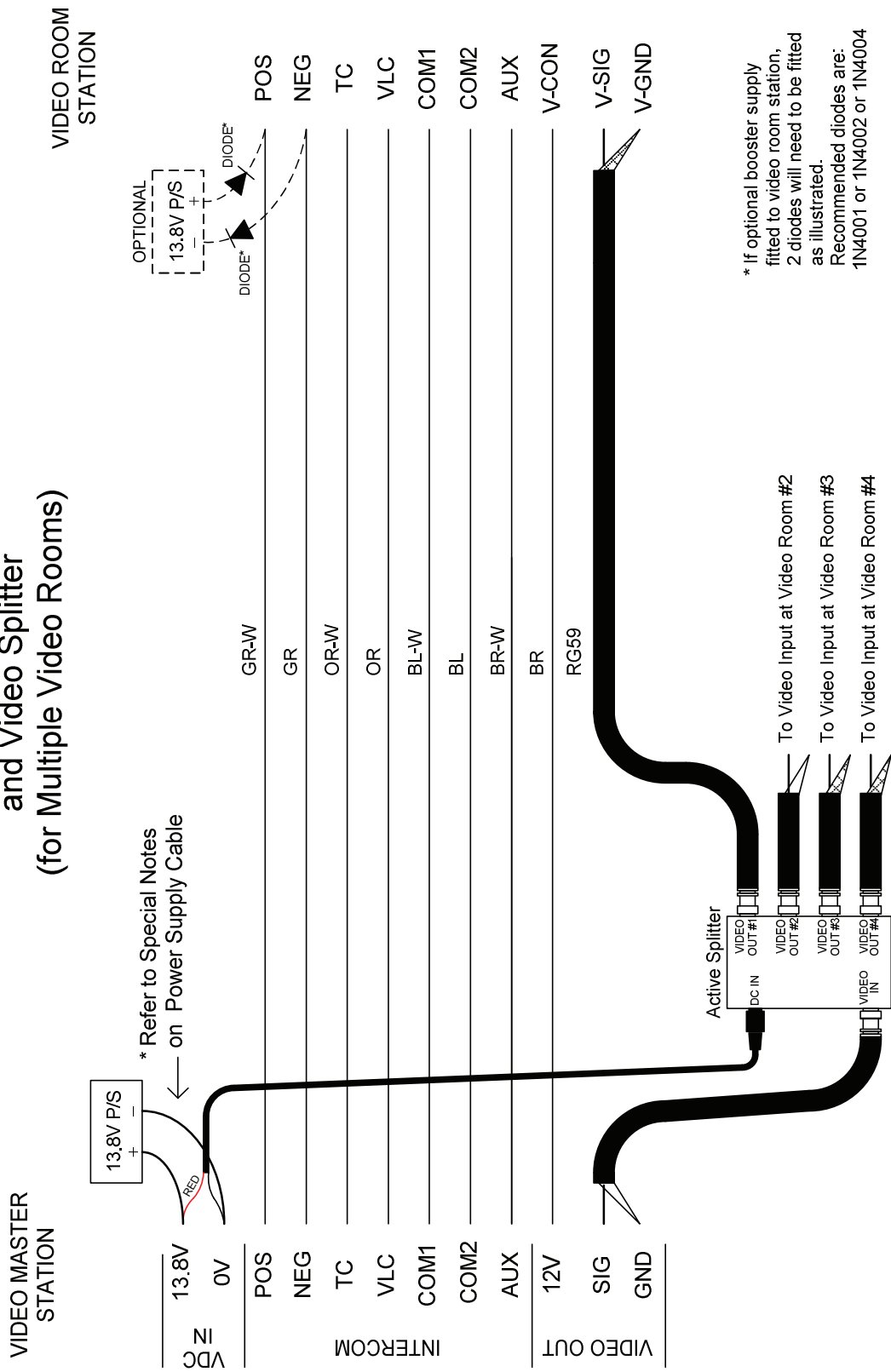

- MASTER
- MULTIPLE VIDEO ROOMS
- VALET CABLE

Connections (System without Master)

Master to Video Room Using VALET Cable and Video Splitter (for Multiple Video Rooms)

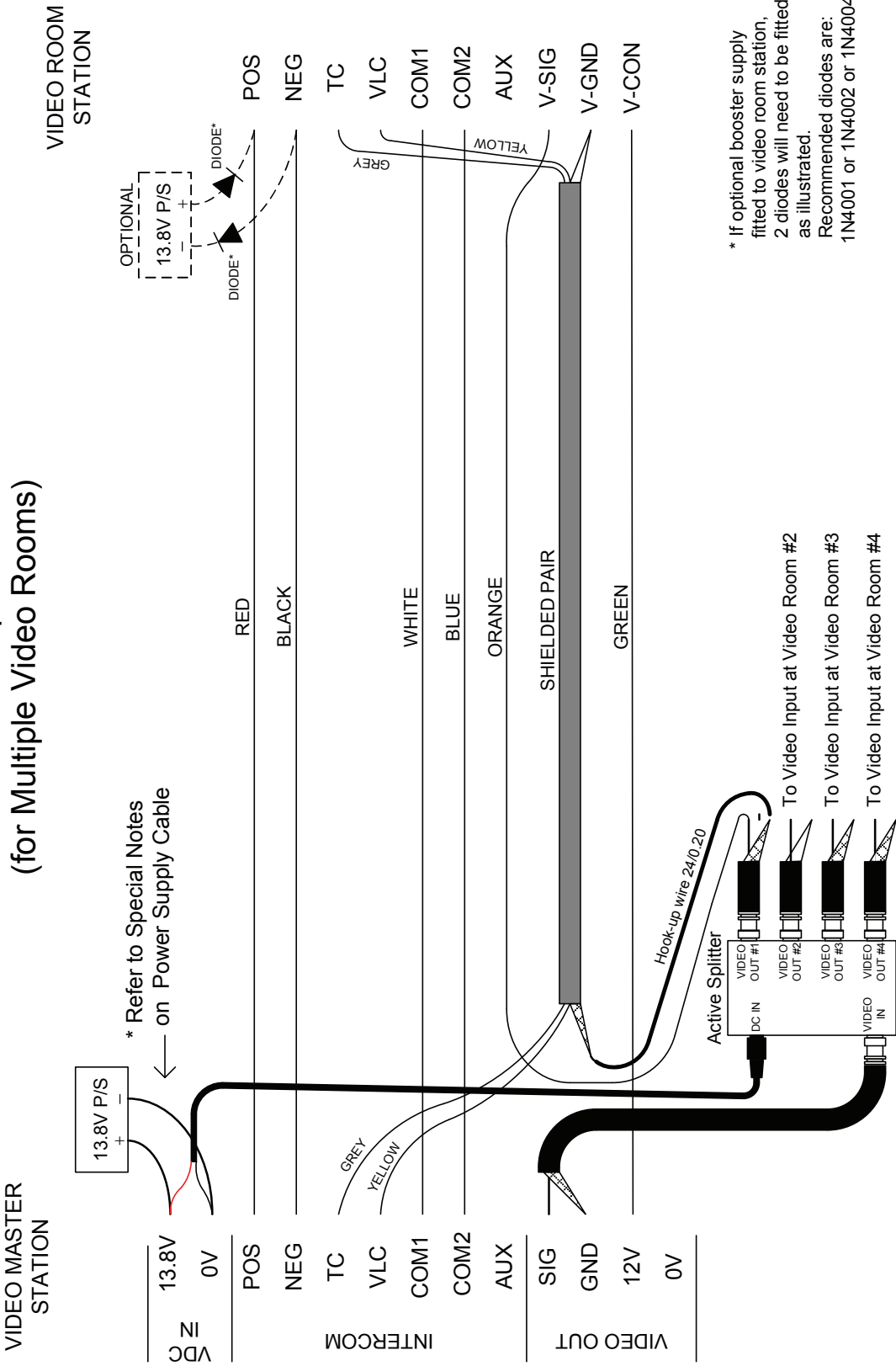

Video Room to Door
Using CAT5 + RG59 Cables
*** No Video Splitter**
(for Connecting Only One Video Room)

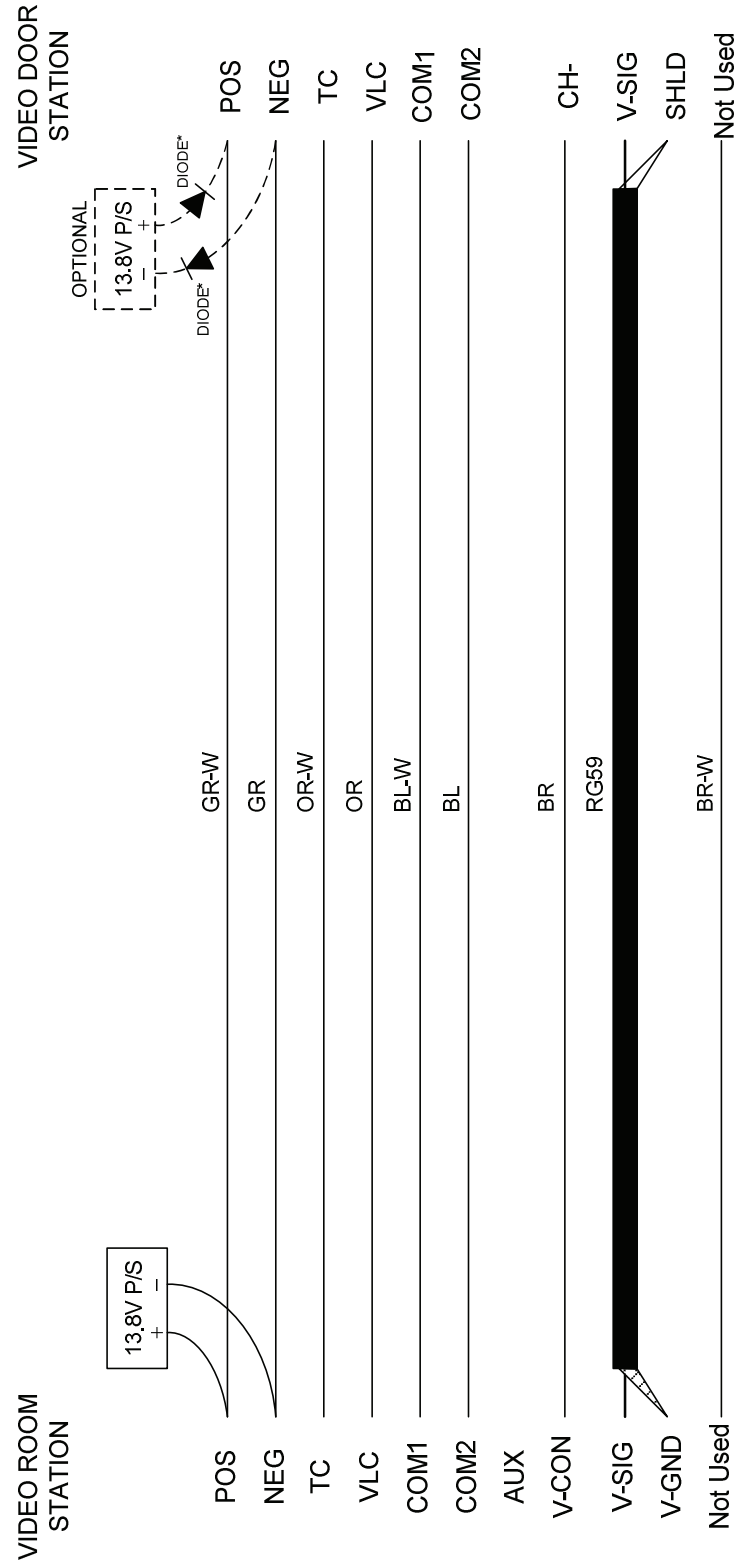

* If optional booster supply fitted to video room station, 2 diodes will need to be fitted as illustrated.
 Recommended diode: 1N4001 or 1N4002 or 1N4004

* Be sure to load the audio lines with the appropriate resistor in relation to the total number of stations connected – See page 9

- NO MASTER
 - ONE VIDEO ROOM
 - CAT5 + RG59

Connections (System without Master)

- NO MASTER
- ONE VIDEO ROOM
- VALET CABLE

Connections (System without Master)

Video Room to Door
Using Valet Cable
*** No Video Splitter**
(for Connecting Only One Video Room)

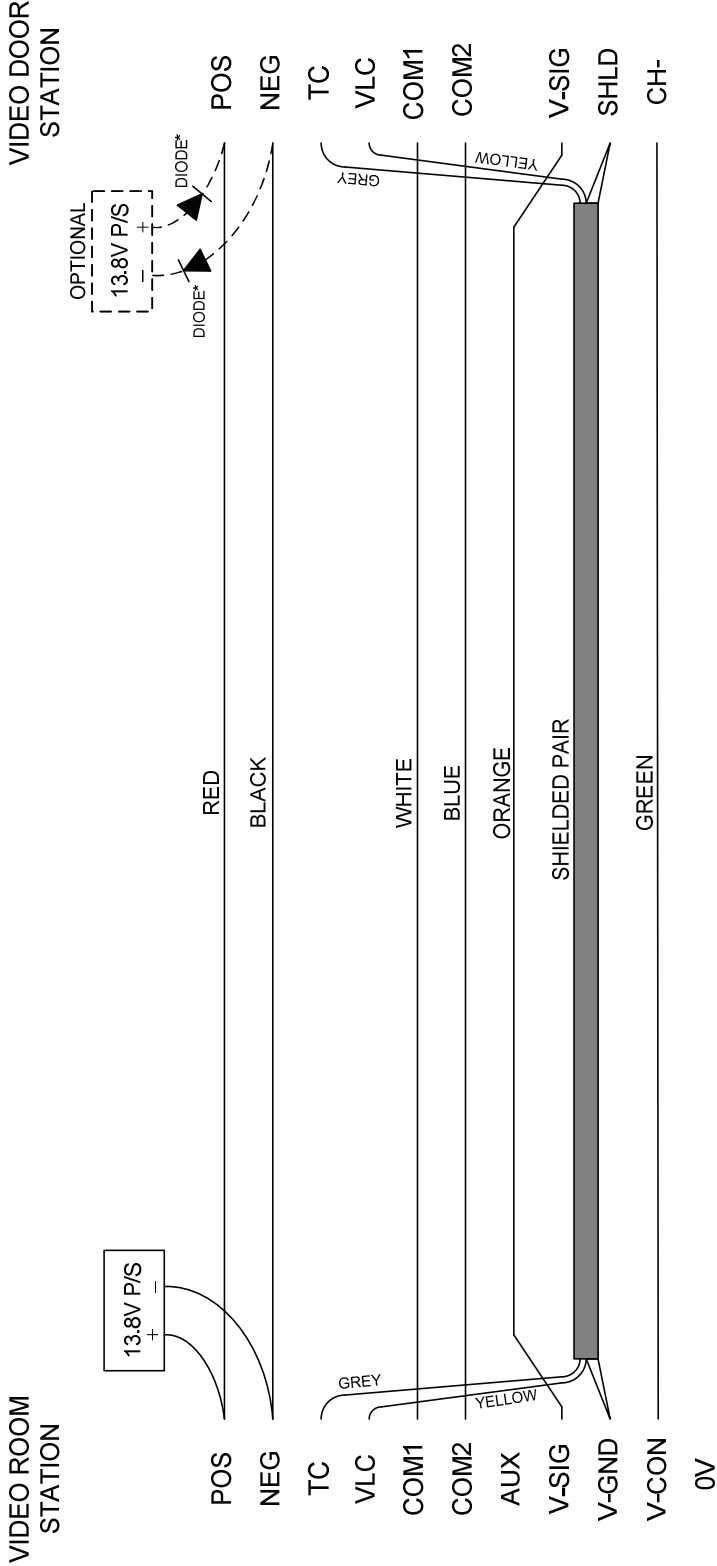

* If optional booster supply fitted to video room station, 2 diodes will need to be fitted as illustrated.
 Recommended diode: 1N4001 or 1N4002 or 1N4004

* Be sure to load the audio lines with the appropriate resistor in relation to the total number of stations connected – See page 9

- NO MASTER
- MULTIPLE VIDEO ROOMS
- CAT5 + RG59

Connections (System without Master)

Video Room to Door Using CAT5 + RG59 Cables and Video Splitter (for Multiple Video Rooms)

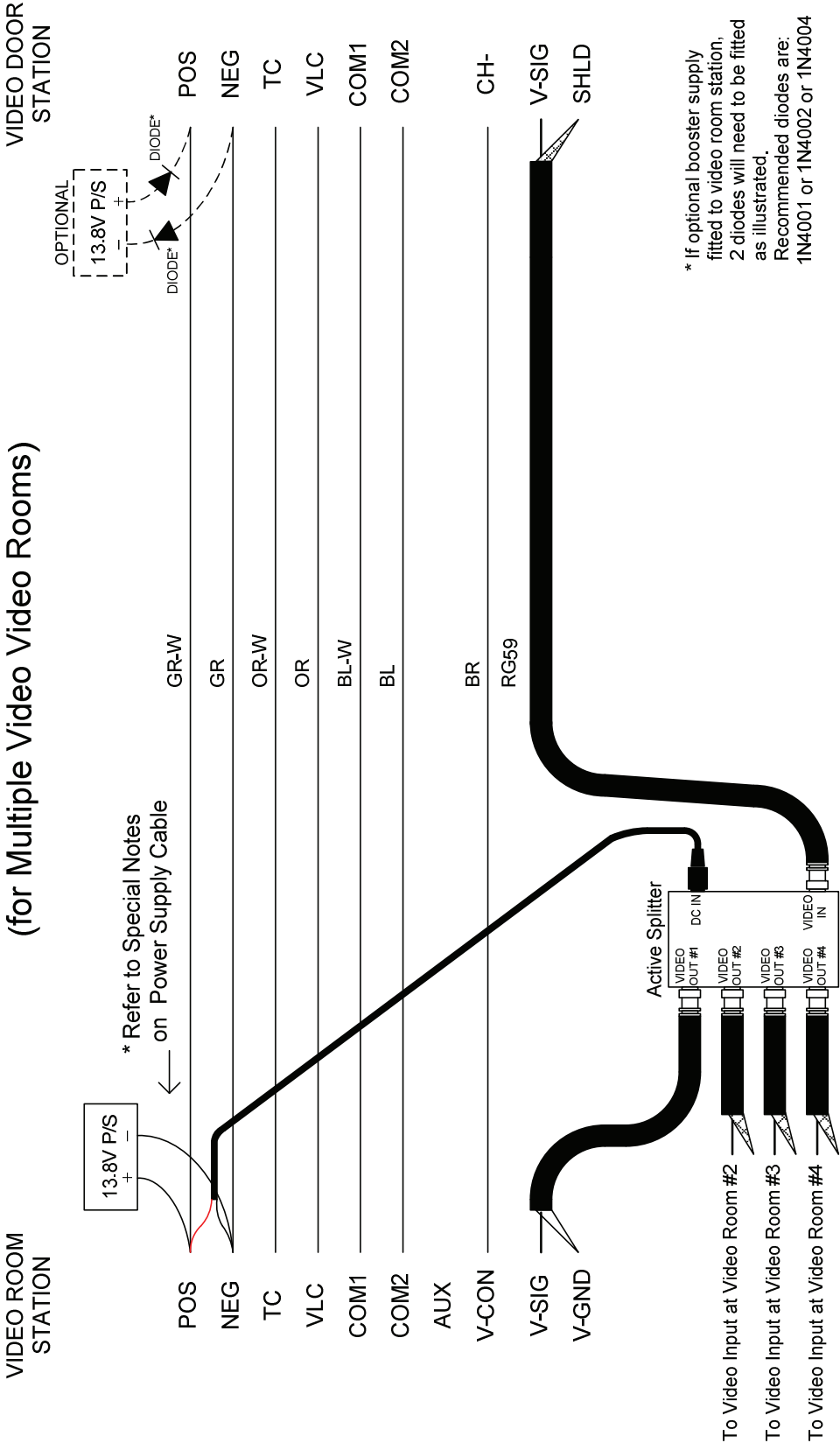

- NO MASTER
- MULTIPLE VIDEO ROOMS
- VALET CABLE

Connections (System without Master)

Video Room to Door Using Valet Cable and Video Splitter (for Multiple Video Rooms)

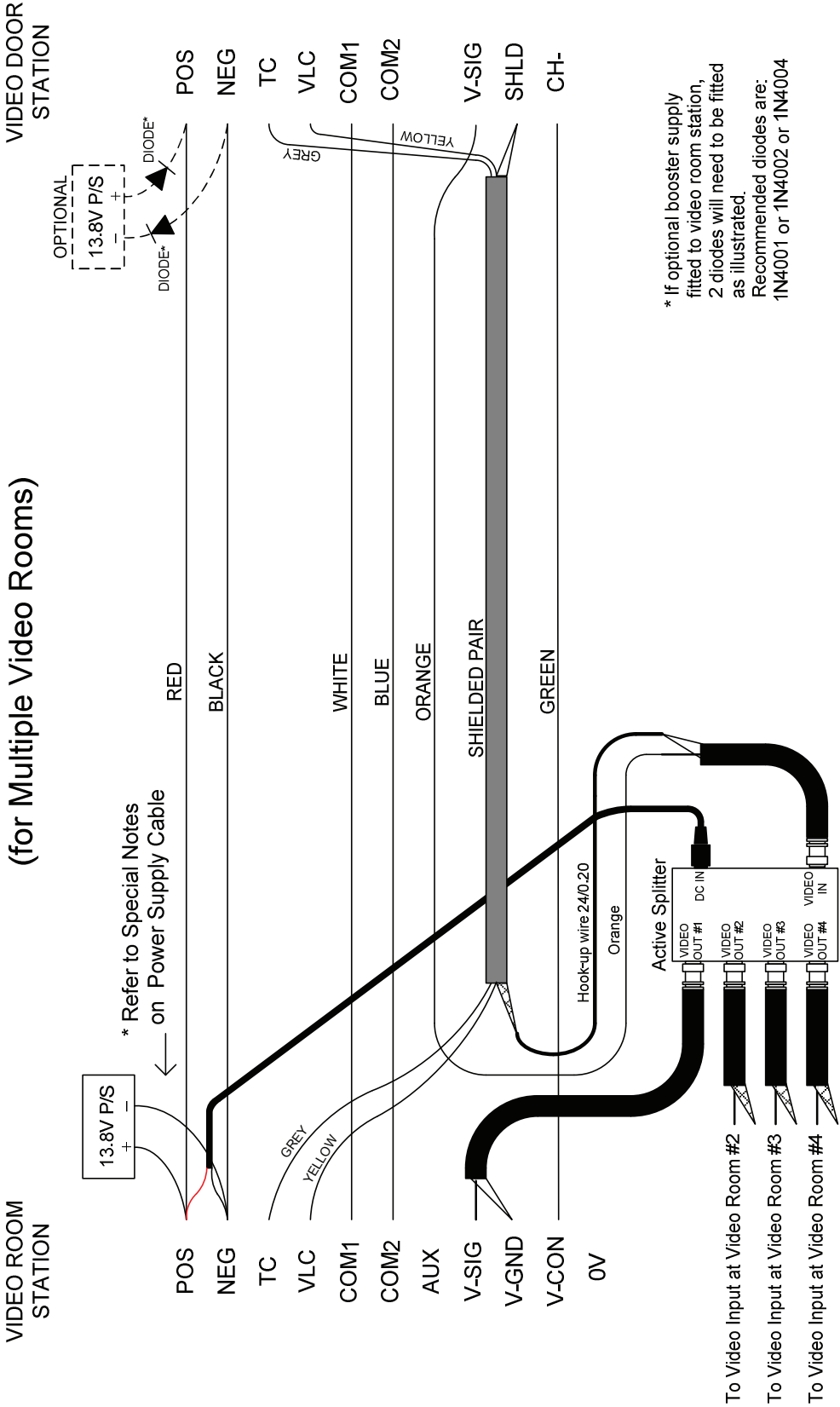

PROGRAMMING

- **PROGRAM MODE**
To enter program mode, press PRIV and MON buttons, both at the same time
 - Green Light ON – Master Mode (Default Setting)
 - Green Light OFF – No Master Mode
 - Red Light Flashing – Station Number (Default = 1)
- **MASTER/NO MASTER MODE**
Use the HOUSE button to configure for use with or without a master station.
 - Green Light ON – for system with a master
 - Green Light OFF – for system without a master
- **KEYPAD BACKLIGHTING**
To change the keypad Backlight level, repeatedly press the DOOR button
 - 3 levels – OFF, MEDIUM & HIGH
- **SINGLE DIGIT/DOUBLE DIGIT MODE**
Use the AUX button to select Single Digit or Double Digit for calling individual stations. (Default Setting = Single Digit)
- **STATION NUMBER**
If set to Single Digit (previous step) press a number button (1 to 7) to program the station number
If set to Double Digit (previous step) press two number buttons in sequence to program the station number - First digit (1 to 3) and second digit (1 to 7)
- **EXIT PROGRAM MODE**
Press the CLEAR button to exit program mode

Single/Double Digit

When calling individual stations, the system can be programmed for Single or Double Digit Dialling (as above).

- Single Digit – For systems with 7 indoor stations (or less)
- Double digit – For systems with 8 indoor stations (or more)

Note: For systems with 8 stations or more, Single Digit Mode can still be used but some stations will need to use duplicate numbers. Stations with duplicate numbers will form a group i.e. Pressing a number button to make a call will address all stations programmed to that number.

Single Digit and Double Digit cannot be used together.
The whole system must be programmed to either Single Digit or Double Digit.

Suggestion: If using the Double digit format for a two storey home, use 1 for the first digit of all stations on the lower storey and 2 for the first digit of all the stations on the upper storey

OPERATION

Calling Other Stations

Door Call

Press and hold the DOOR button to speak to the door station

Release the DOOR button to listen to the *hands free reply** from the door station

Press and hold the DOOR button again to continue the conversation

The Video Screen will display an image from the camera for the duration of communication

To end the call, press the CLEAR button or just allow the call to time out (20 sec)

House Call

Press and hold the HOUSE button to speak to all other stations

Release the HOUSE button to listen to the *hands free reply** from any of the other stations

Press and hold the HOUSE button again to continue the conversation

To end the call, press the CLEAR button or just allow the call to time out (20 sec)

Select Call

For systems programmed for Single Digit Dialling:

Press and hold a number button (1 to 7) to speak to an individual station

Release the number button to listen to the *hands free reply** from the other station

Press and hold the number button again to continue the conversation

To end the call, press the CLEAR button or just allow the call to time out (20 sec)

For systems programmed for Double Digit Dialling:

Press the first digit (1 to 3)

Press and hold the second digit (1 to 7) to speak to an individual station

Release the second digit to listen to the reply

Press and hold the second digit again to continue the conversation

To end the call, press the CLEAR button or just allow the call to time out (20 sec)

Green Light

The green light will turn On when pressing a button to speak and will turn Off when the button is released to listen

Red Light

The red light will Flash for the duration of the conversation and will turn Off when the call times out (or is cancelled by pressing the CLEAR button)

Communication Volume

Volume for communication (and Chime) can be adjusted while receiving communication (or Chime) without having any affect on the volume setting for music.

* Hands Free Reply: The person replying does not need to press any buttons
– just speak to reply

Operating Modes

Privacy Mode

Press the PRIV button to activate Privacy mode

- The green light flashes
- Automatic hands free reply is disabled from this station, preventing anyone at another station “listening in” to a private conversation.

Music Mode

Press the MUS button to activate Music mode

- The red light turns on
- Music playing through the system will be heard at this station
- Music volume can be adjusted without affecting chime or communication volume

Monitor Mode

Press the MON button to activate Monitor mode

- The green light turns on indicating the microphone is active
- Any sound being picked up by the microphone at this station can be heard at any other station set to Music mode
- Door chime and general communication will not be heard at this station
- Select calls made to this station will be heard
- Press the MON button again to turn off monitor mode

Note: Music Source (i.e. Radio) should be turned off at master when Monitor mode is in use.

Do Not Disturb Mode

Press and hold the MUS button for 3 seconds to activate Do Not Disturb mode

- The Red light will flash (one quick flash per second)
- Door chime and general communication will not be heard at this station
- Select calls made to this station will be heard
- Press the MUS button to turn off Do Not Disturb mode

Lock Control

For a system without a master

Pressing the LOCK button will activate the lock output* at any time.

For a system with a master

Pressing the LOCK button, while communicating with the door station, will activate the lock output*

*Only applicable where automatic gates, or an optional electric lock, have been connected to the system.

Video Operation

In Response to the Chime

When the chime is activated at the door station, the video image will be displayed at the video room station and will reset after 30 seconds if unanswered.

Note: When used without a master, the display time above can be extended to 60 seconds by changing the CH programming at the door station from Option #1 to Option #3

During Communication

If communication to the door is initiated from the video room station, the video image will be displayed until the call is cancelled or times out.

Video Monitoring

The video image from the camera (or any one of three cameras on a system with a master) can be monitored by the video room station on command.

For a system without a master:

- To display the video image from the door station – Press AUX and then press 5
- Video monitoring will automatically reset after 30 min.
- To manually reset video monitoring – Press AUX and then HOUSE (or again press AUX and then 5)

For a system with a master, programmed to Single Digit and with auxiliary circuit wired:

- To display the video image from camera #1 – Press AUX and then press 5
- To display the video image from camera #2 – Press AUX and then press 6
- To display the video image from camera #3 – Press AUX and then press 7
- Video monitoring will automatically reset after 90 min
- To manually reset video monitoring – Press AUX and then press HOUSE (or press AUX and then press the number corresponding to the active camera 5, 6 or 7)

For a system with a master and programmed to Double Digit:

- To display the video image from camera #1 – Press 7 and then press 5
- To display the video image from camera #2 – Press 7 and then press 6
- To display the video image from camera #3 – Press 7 and then press 7
- Video monitoring will automatically reset after 90 min
- To manually reset video monitoring – Press 7 and then press HOUSE (or press 7 and then press the number corresponding to the active camera 5, 6 or 7)

Note: For systems with a master, programmed to Double Digit mode, Camera Monitoring and Auxiliary Outputs can be activated without having the auxiliary circuit wired.

Systems with a master, programmed to Single Digit mode, will require the auxiliary circuit to be wired to allow activation of Camera Monitoring and Auxiliary Outputs.

iCentralTM
Intelligent Central Systems
A DIVISION OF **NEFF** CORPORATION

SYSTEM
ONETM